

# Rexroth Fieldline Modular M8 Device With 8 Digital Inputs

**R911170494**  
Edition 02

## RF-FLM DI 8 M8

8 digital inputs  
DC 24V

02/2007



### Description

The device is designed for use on the Fieldline modular M8 local bus, which is opened by a Fieldline or Inline bus coupler. It is used to acquire digital signals.

### Features

- Connection to the Fieldline modular local bus using M8 connectors
- Connection of digital sensors using M8 connectors
- Flexible voltage supply concept
- Diagnostic and status indicators
- Short-circuit and overload protection of the sensor supply
- IP 65/67 protection



This data sheet is only valid in association with the application description DOK-CONTRL-FLSYS-INS\*\*\*-AW..-EN-P or the application description for your bus system, see "[Documentation](#)" on page 2.



Make sure you always use the latest documentation. It can be downloaded at [www.boschrexroth.com](http://www.boschrexroth.com).

## Ordering Data

### Product

Description	Type	MNR	Pcs./Pkt.
Fieldline modular M8 device with 8 digital inputs	RF-FLM DI 8 M8	R911170449	1

### Documentation

Description	Type	MNR	Pcs./Pkt.
"Installing the Rexroth Fieldline Product Range" application description	DOK-CONTRL-FL-SYSINS***-AW...-EN-P	R911317026	1
"Configuring the INTERBUS System using devices of the Rexroth Fieldline product range" application description	DOK-CONTRL-FLSIB-SYSPRO-AW...-EN-P	R911317947	1
"Configuring a PROFIBUS DP System using devices of the Rexroth Fieldline product range" application description	DOK-CONTRL-FLSPB-SYSPRO-AW...-EN-P	R911317945	1
"Configuring the DeviceNet System using devices of the Rexroth Fieldline product range" application description	DOK-CONTRL-FLSDN-SYSPRO-AW...-EN-P	R911317949	1



For further ordering data (accessories), please refer to our product catalog at [www.boschrexroth.com](http://www.boschrexroth.com).

## Technical Data

### Dimensions of the Module

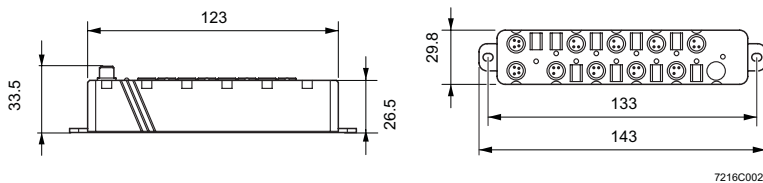

### General Data

Dimensions (width x height (incl. fixing clips) x depth)	29.8 mm x 143 mm x 33.5 mm
Weight	137 g
Operating mode	Process data mode with 8 bits
Transmission speed	500 kbps
Connection method for sensors	2 and 3-wire technology
Permissible temperature (operation)	-25°C to +60°C
Permissible temperature (storage/transport)	-25°C to +85°C
Permissible humidity (operation)	5% to 95%
Permissible humidity (storage/transport)	10% to 95%
Permissible air pressure (operation)	80 kPa to 106 kPa (up to 2,000 m above sea level)
Permissible air pressure (storage/transport)	70 kPa to 106 kPa (up to 3,000 m above sea level)
Degree of protection	IP 65/67 according to IEC 60529
Class of protection	Class 3 according to VDE 0106, IEC 60536

### Mechanical Requirements

Sinusoidal vibrations according to EN 60068-2-6	5g load in each space direction
Shock test according to EN 60068-2-27	30g load, half sinusoidal wave positive and negative in each space direction



For additional information on mechanical requirements and ambient conditions, please contact Bosch Rexroth.

**Power Supply**

Nominal value	24 V DC
Tolerance	± 25% incl. 5% ripple
Current consumption $U_{LS}$ at 24 V DC	30 mA, typical (40 mA, max.) + sensor current (600 mA, max.)

**Digital Inputs**

Number	8
Input design	According to IEC 61131-2 Type 1
Definition of switching thresholds	
Maximum low-level voltage	$U_{Lmax} < 5 \text{ V}$
Minimum high-level voltage	$U_{Hmin} > 11 \text{ V}$
Nominal input voltage	24 V DC
Range	$-30 \text{ V DC} < U_{IN} < + 30 \text{ V DC}$
Nominal input current	5 mA
Current flow	Linear in the range $2 \text{ V} < U_{IN} < 30 \text{ V}$
Delay time	$t_{ON} < 1 \text{ ms}$ , typical $t_{OFF} < 1 \text{ ms}$ , typical
Permissible cable length to the sensor	< 30 m

**Input Characteristic Curve**

Input Voltage (V)	Typical Input Current (mA)
$-30 < U_{IN} < 0.7$	0
3	0.5
6	1.0
9	1.6
12	2.3
15	3.0
18	3.8
21	4.5
24	5.2
27	6.0
30	6.7

**Sensor Supply**

Minimum sensor voltage	$U_S - 1 \text{ V}$
Nominal current per channel	600 mA
Nominal current per device	600 mA
Overload protection	Electronic per device
Short-circuit protection	Electronic per device

**Error Messages to the Higher-Level Control or Computer System**

Sensor supply short circuit	Yes
Sensor supply overload	Yes



If an error is triggered by an overload or short circuit of the sensor supply, the device switches off the sensor supply of the channels and reports an I/O error message to the master.

**Interface**

Bus system	Fieldline modular M8 local bus
------------	--------------------------------

**Incoming bus**

Coupling of shield connection	Directly to FE
Transmission speed	500 kbps

**Outgoing bus**

Coupling of shield connection	Directly to FE
Transmission speed	500 kbps

**Electrical Isolation/Isolation of the Voltage Areas**

For device connection, please note the instructions and regulations in the "Installing the Rexroth Fieldline Product Range" application description DOK-CONTRL-FLSYSINS\*\*\*-AW...-EN-P.

**Separate Potentials in the RF-FLM DI 8 M8****Test Distance****Test Voltage**

FE / 24 V supply (sensor supply and logic supply and inputs)	500 V AC, 50 Hz, 1 min.
FE / logic (logic / incoming bus / outgoing bus)	500 V AC, 50 Hz, 1 min.
24 V supply (sensor supply and logic supply and inputs) / logic (logic / incoming bus / outgoing bus)	500 V AC, 50 Hz, 1 min.

**Approvals**

For the latest approvals, please visit [www.boschrexroth.com](http://www.boschrexroth.com).

### Pin Assignment

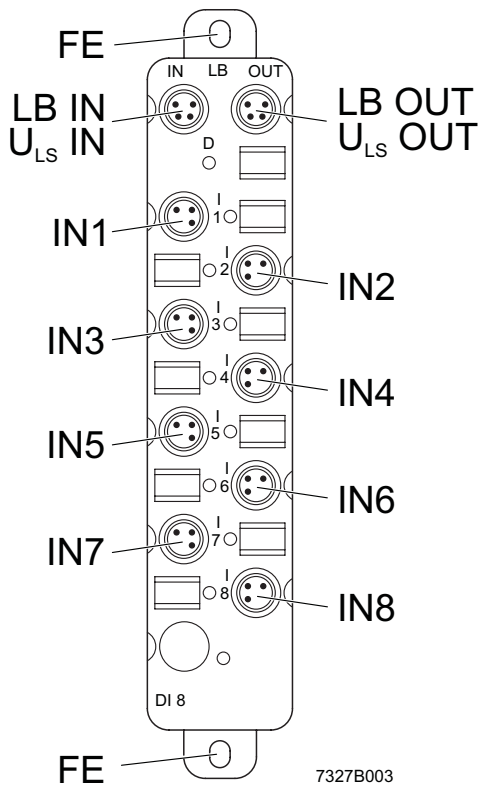

Fig. 1 Connections of the RF-FLM DI 8 M8 device

### Pin Assignment of LB IN / LB OUT

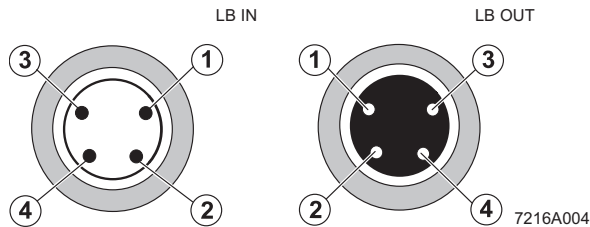

Fig. 2 Pin Assignment of LB IN/LB OUT

Des.	Meaning
FE	Functional earth ground
LB IN	Local bus IN
LB OUT	Local bus OUT
U <sub>LS</sub> IN	Power supply IN (logic and sensor supply)
U <sub>LS</sub> OUT	Power supply OUT (supply for additional devices)
IN1 to IN8	Inputs 1 to 8



In general, the maximum current load of 3 A per contact must not be exceeded.

**CAUTION**

Pin	IN	OUT
1	Supply voltage U <sub>LS</sub> (logic and sensor supply)	Voltage supply U <sub>LS</sub> (device and sensors)
2	DI	DO
3	GND U <sub>LS</sub>	GND U <sub>LS</sub>
4	DI	DO

The thread is used for shielding.



**CAUTION**

**Pin Assignment of the Inputs**

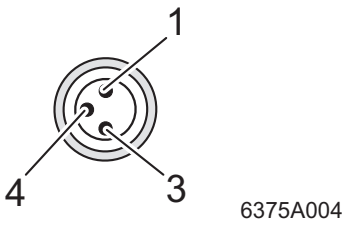

Fig. 3 Pin assignment of the inputs

Pin	Female Input Connector
1	24 V U <sub>S</sub> supply voltage for sensors
3	GND U <sub>LS</sub>
4	Input

**Local Diagnostic and Status Indicators**

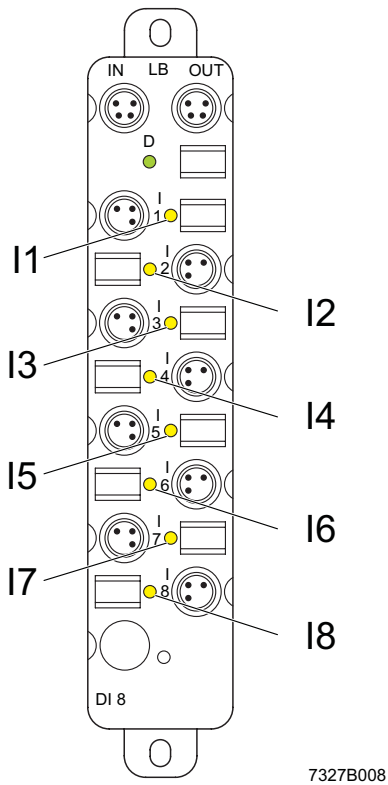
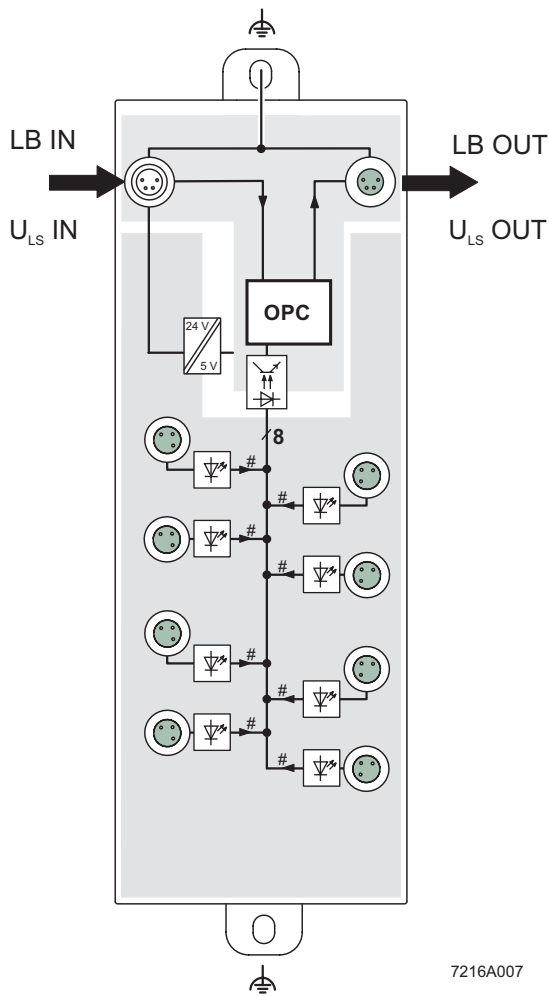









Fig. 4 LED diagnostic and status indicators of the RF-FLM DI 8 M8

Des.	Color	Meaning
<b>D</b>	Green LED	Diagnostics
	ON:	Bus active
	Flashing, 0.5 Hz	Communications power present, bus is not active
	Flashing, 2 Hz	Communications power present, I/O error is present, Sensor supply overload
	Flashing, 4 Hz	Communications power present, transmission path to the left of the flashing device failed, device to the left of the flashing device failed, devices to the right of the flashing device are not part of the configuration frame
	OFF:	Communications power not present, bus not active
<b>I1 to I8</b>	Yellow LED	Status indicators of the inputs
	ON:	Input active
	OFF:	Input not active

### Internal Circuit Diagram



Key:

-  Functional earth ground
-  Protocol chip (bus logic incl. voltage conditioning)
-  Power supply unit with electrical isolation
-  Optocoupler
-  LED
-  Input
-  Electrically isolated area

 For information on electrically isolated areas, please refer to [page 4](#).

7216A007

Fig. 5 Internal wiring of the connection points

## Connection Example

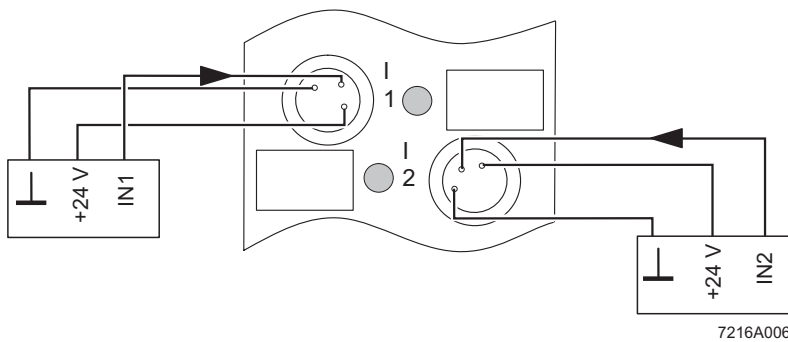

Fig. 6 Typical sensor connections

## Connection Notes



**CAUTION**

### Meet noise immunity requirements!

Realize the FE connection via a fixing screw when connecting the sensor to a non-conductive surface. When mounting the sensor onto a non-conductive surface, the FE connection is realized via a cable lug using a fixing screw.



Fix the device to a level surface or to a profile. Do not use this device to bridge gaps, i.e., to prevent forces to be transmitted via the device.



**CAUTION**

### Ensure degree of protection

To ensure IP65/IP67 protection, cover unused female connectors with protective caps.



Tighten the fixing screw at the girder metal sheet with a maximum of 2.8 Nm.



**CAUTION**

### Avoid damage to the electronics

Make sure you only supply the sensors with the voltage  $U_S$  provided at the connection points.



Also connect a large part of the filler litz wire to the connectors of the local bus cables with braided shield.



**CAUTION**

### Avoid polarity reversal

Avoid polarity reversal of the supply voltages  $U_{LS}$  to avoid damage to the device.



**CAUTION**

### Observe connection point assignment

When connecting the sensors, observe the assignment of the connection points to the IN process data (see "[Process Data](#)" on page 9).



## Programming Data/Configuration Data

### Local Bus

ID code	B2 <sub>hex</sub> (178 <sub>dec</sub> )
Length code	81 <sub>hex</sub>
Process data channel	8 bits
Input address area	8 bits
Parameter channel (PCP)	0 bits
Register length (bus)	8 bits

### Other Bus Systems



For the programming data of other bus systems, please refer to the appropriate electronic device data sheet (e.g. GSD, EDS).

For additional information, please refer to the application descriptions, see "[Pin Assignment](#)" on page 5

## Process Data

### Assignment of the Connection Points to the IN Process Data

(Byte.bit) view	Byte	Byte 0							
	Bit	7	6	5	4	3	2	1	0
Device	Input	8	7	6	5	4	3	2	1

**Notes:**

DOK-CONTRL-  
FLMDI8\*\*\*\*\*-KB02-EN-P

Bosch Rexroth AG  
Electric Drives and Controls  
P.O.Box 13 57  
97803 Lohr, Germany  
Bgm.-Dr.-Nebel-Str. 2  
97816 Lohr, Germany  
Tel. +49-(0) 93 52 - 40-50 60  
Fax. +49-(0) 93 52 - 40-49 41  
service.svc@boschrexroth.de  
[www.boschrexroth.com](http://www.boschrexroth.com)

All rights reserved. No part of this document may be reproduced or stored, processed, duplicated or circulated using electronic systems, in any form or by any means, without the prior written authorization of Bosch Rexroth AG, Electric Drives and Controls. Violations shall give rise to claims for damages. The data specified above only serve to describe the product. They do not indicate any specific condition or suitability for a certain application. The information provided does not release the user from the obligation of own judgement and verification. It must be remembered that our products are subject to natural wear and aging.

**Reprint forbidden - subject to modifications**